



# The Ductless is *in* Trend

Avoid up to **30%** energy loss due to ductwork



Flexible installation without ductwork, ideal for whole home, addition or conversion



Precisely cool & heat the needed spaces/ spots

## Where Will You Need An IN?

In some spaces, built-in products might be a better fit in terms of aesthetics.



**Built-*in* Design**  
**Fit-*in* Size**  
**Blend-*in* Style**  
Meet the new solution of ductless split



www.mideacomfort.us



www.mideacomfortna.ca

1. Not enough space for a highwall unit installation



2. The dimensions of current ceiling cassette don't fit in the common joist space

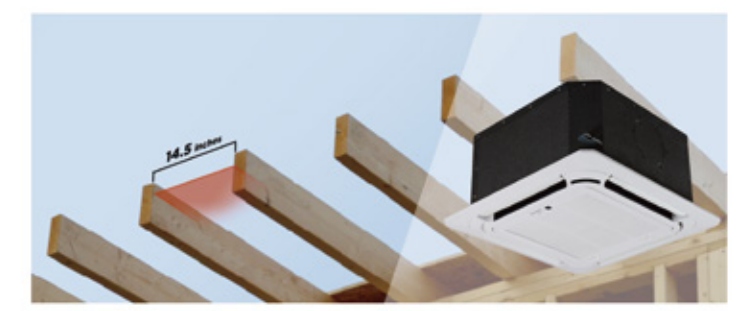

3. Too many obstructions on the ceiling

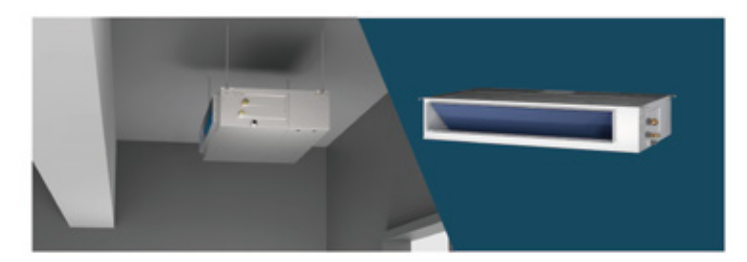

# A solution is *in* Midea IN Cassette



## Industry exclusive compact size

Midea IN Cassette is ready-to-fit into the home joist spaces, making it an ideal option for new home, additional spaces, and conversion at a later date.

Unit Width  
**13-1/4 inches**



Unit length  
**50-3/8 inches**

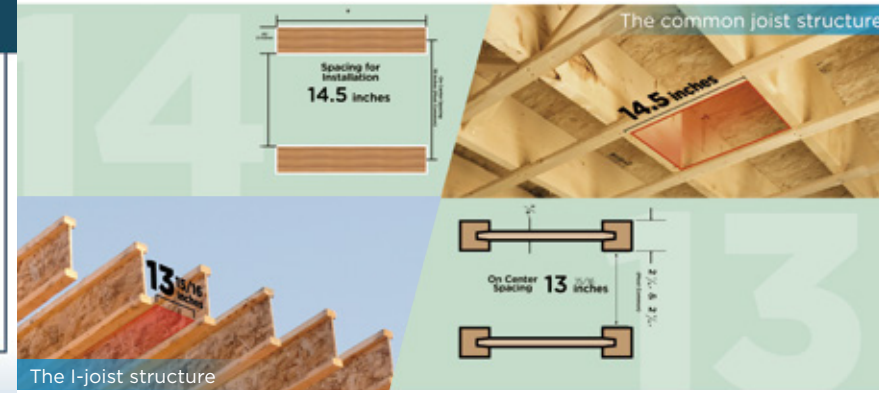

## Fit-*in* Space Blend-*in* Design

Probably one of the most versatile indoor units ever

Larger area such as living room



When no one at home in cold days



Smaller room with limited installation space

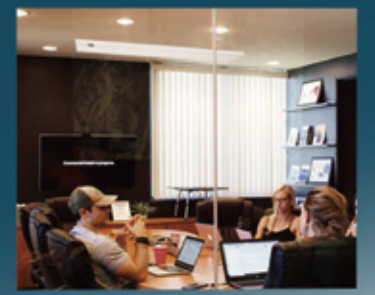
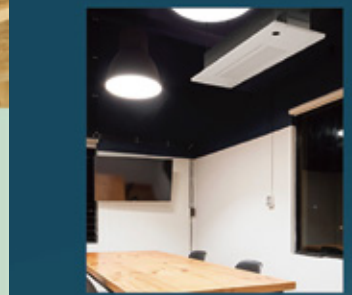

Ductless fans can't handle accumulating debris, to maintain the unit, homeowners will have to wash the unit filter monthly (more often if you smoke or have pets).

## And now, even daily-based maintenance gets easy with Elevation Panel

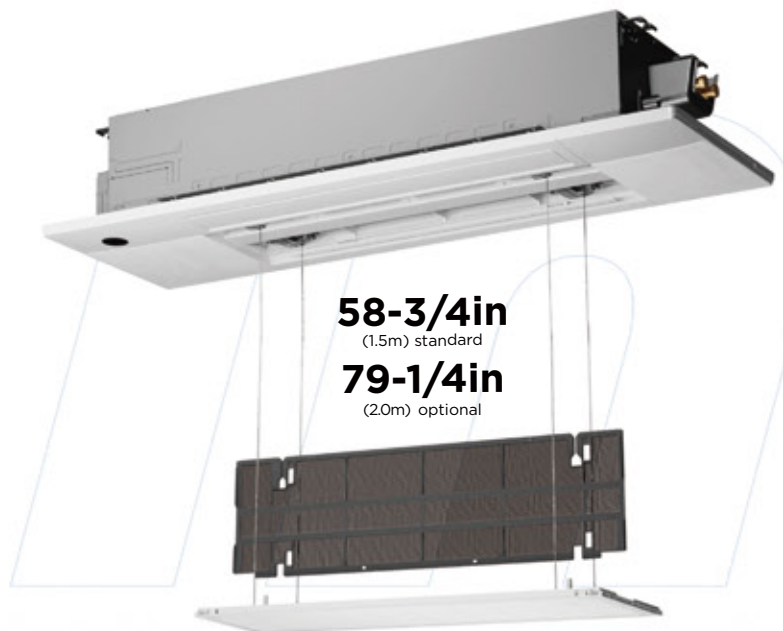

58-3/4in  
(1.5m) standard  
79-1/4in  
(2.0m) optional

No more climbing up and down, as the Elevation Panel itself can lower and raise. By activating the Elevation Panel function on the remote, or smart controller, the panel will go straight down to you for easy filter access.

The adjustable rope lengths can be set at 5' or 6.5' for different access levels.

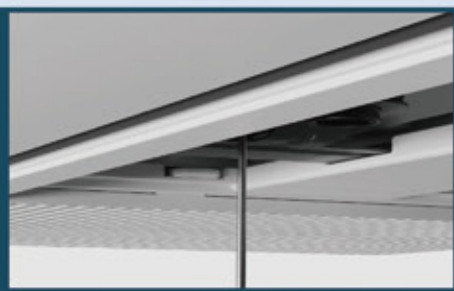

## Take into account the contractors Industry exclusive 2-way installation



### 1. HangUp Installation



Our hangers with optimized anti-cutting design are easy to grab and lift up, preventing hands from scratching by the sharp edge.

Products in 2024



### 2. PushIn Installation

The unique & exclusive screws-in design for easy installation options. Installers can plug in the IN-cassette unit between the joist and fix it on the beams with screws.



Double Row Tack Holes Design adapt to various joint size

## Built-in water pump



The built-in water pump can discharge the condensate water. No need to add an extra water pump to the side of the unit.

## Easy-to-access Core Components

Adopting the design of the high wall split, installers only have to open the front panel to gain access to PCB box sections.



## Integrated Package Design



Save the logistics spaces and easy to bring to the installation site

### One-Way Cassette Extreme Heat\_Specification Up to 24 SEER2

Model	Indoor Unit	MCAHU-H06B-2A	MCAHU-H09B-2A	MCAHU-H12B-2A	MCAHU-H18B-2A
	Outdoor Unit	MOIHS-H06B-2A	MOIHS-H09B-2A	MOIHS-H12B-2A	MOIHS-H18B-2A

Performance						
Power Supply		V, Ph, Hz	208/230V,1Ph, 60Hz	208/230V,1Ph, 60Hz	208/230V,1Ph, 60Hz	208/230V,1Ph, 60Hz
SEER2 (AHRI 210/240 - 2023)	Cooling/Heating Capacity	Btu/h	6,500/7,400	9,000/10,900	12,000/12,500	16,700/20,000
	SEER2	Btu/W	22.0	24.0	23	20.6
	EER2	Btu/W	15	14.6	13	12.5
Heating at 5°F (-15°C)	HSPF4	Btu/W	12.0	12.1	10	12.2
	Rated capacity	Btu/h	8,100	10,600	11,500	17,500
	COP	W/W	2.40	1.83	2.0	1.89

Indoor unit						
Air Flow Volume	Turbo/Hi/Mi/Lo/Si	CFM	341/294/259/235/235	341/294/259/235/235	353/312/283/247/177	400/352/300/207/207
Noise Level	Turbo/Hi/Mi/Lo/Si	dB(A)	47/38/36/26/24	38/38/36/33/24	41/41/37/33/24	44/44/42/31/26
Net Dimension	WxDxH	mm	1278×335×228	1278×335×228	1278×335×228	1278×335×228
	WxDxH	inch	50-1/4×13-1/4×9	50-1/4×13-1/4×9	50-1/4×13-1/4×9	50-1/4×13-1/4×9
Packing Dimension	WxDxH	mm	1463×571×575	1463×571×575	1463×571×575	1463×571×575
	WxDxH	inch	57-5/8×22-1/2×22-5/8	57-5/8×22-1/2×22-5/8	57-5/8×22-1/2×22-5/8	57-5/8×22-1/2×22-5/8
Net/Gross Weight		kg	20.5/37.4	20.5/37.4	20.5/37.4	20.5/37.6
		lbs	45/82	45/82	45/82	45/82

### One-Way Cassette Energy Star\_Specification Up to 22.2 SEER2

Model	Indoor Unit	MCAHU-H09B-2A	MCAHU-H12B-2A	MCAHU-H18B-2A
	Outdoor Unit	MOIES-H09B-2A	MOIES-H12B-2A	MOIES-H18B-2A

Performance					
Power Supply		V, Ph, Hz	208/230V,1Ph, 60Hz	208/230V,1Ph, 60Hz	208/230V,1Ph, 60Hz
SEER2 (AHRI 210/240 - 2023)	Cooling/Heating Capacity	Btu/h	9,000/11,000	12,000/12,000	18,000/18,000
	SEER2	Btu/W	22.1	22.1	22.2
	EER2	Btu/W	14.4	12.3	12.5
Heating at 5°F (-15°C)	HSPF4	Btu/W	11.8	10	12.2
	Rated capacity	Btu/h	8,000	8,600	13,100
	COP	W/W	2.18	2.48	2.24

Indoor unit					
Air Flow Volume	Turbo/Hi/Mi/Lo/Si	CFM	341/294/259/235/235	353/312/283/247/177	400/352/300/207/207
Noise Level	Turbo/Hi/Mi/Lo/Si	dB(A)	47/38/36/26/24	43/43/38/26/22	44/44/41/30/24
Net Dimension	WxDxH	mm	1278×335×228	1278×335×228	1278×335×228
	WxDxH	inch	50-1/4×13-1/4×9	50-1/4×13-1/4×9	50-1/4×13-1/4×9
Packing Dimension	WxDxH	mm	1463×571×575	1463×571×575	1463×571×575
	WxDxH	inch	57-5/8×22-1/2×22-5/8	57-5/8×22-1/2×22-5/8	57-5/8×22-1/2×22-5/8
Net/Gross Weight		kg	20.5/37.4	20.5/37.4	20.5/37.6
		lbs	45/82	45/82	45/82

\*Future Products in 2024