

R454b Refrigerant

SUBMITTAL DATA SHEET



Series Name: Multi-Zone Mid Tier Advanced Heat Without Shut-off Valve_All Non-Ducted
Model Number: MO4DX-H27B-2A

Multi Zone Heat Pump System

Location:	Approval:
Engineer:	Date:
Submitted to:	Construction:
Submitted by:	Unit #:
Reference:	Drawing #:



OUTDOOR SPECIFICATION

Compressor Type	TWIN-ROTARY	
Compressor Model	KTM240D46UKT2	
Refrigerant	R454B	
Refrigerant Oil Charge(mL)	620	
Refrigerant Oil	V74	
Outdoor Air Flow (Max) (CFM)	2,130.7	
Outdoor Noise Level (dBA)	61.0	
Dimension (W×D×H)	inch	37-1/4 x 16-1/8 x 31-7/8
	mm	946 x 410 x 810
Package (W×D×H)	inch	42-7/8 x 19-5/8 x 34-7/8
	mm	1,090 x 500 x 885
Net/Gross Weight	lbs	138 / 149
	kg	62.7 / 67.6

ELECTRICAL

Power Supply	208/230V,60Hz,1Ph
System MCA	23.0
Connection Wiring	AWG 14/4
System MOCP	25.0
Compressor RLA	12.1
Outdoor Fan Motor RLA	1.2
Outdoor Fan Motor W	120
Indoor Fan Motor RLA	/
Indoor Fan Motor W	/
System Power Input @ Cooling (W)	2,080 (500 ~ 2,730)
System Power Input @ Heating (W)	2,080 (500 ~ 2,400)
MCA: Min. circuit amps (A)	MOCP: Max. over current protection (A)
RLA: Rated load amps (A)	W: Fan motor rated output (W)

EFFICIENCY

Cooling		Heating	
SEER2	25.0	HSPF2-4	9.5
EER2	13	COP	3.8

PERFORMANCE of Cooling

Cooling (Btu/hr)	
Rated Capacity	27,000
Min/Max Capacity	7,200 ~ 32,000
Moisture Removal(L/h)	0.8
Standard Operating Range(*F/*C)	-13~122 (-25~50)
Rated Cooling Conditions:	Indoor: 80°F DB/67°F WB Outdoor: 95°F DB/75°F WB

PERFORMANCE of Heating

Heating (Btu/hr)	
1. @ 47°F Rated	27,000
1. @ 47°F Min/Max Capacity	8,400 ~ 29,000
2. @ 17°F Rated(H32)	18,400
3. @ 5°F Rated: Capacity / COP(H42)	19,000 / 2
3. @ 5°F Max: Capacity	19,000
Standard Operating Range(*F/*C)	-13~75 (-25~24)
1. Conditions:	Indoor: 70°F DB/60°F WB Outdoor: 47°F DB/43°F WB
2. Conditions:	Indoor: 70°F DB/60°F WB Outdoor: 17°F DB/15°F WB
3. Conditions:	Indoor: 70°F DB/60°F WB Outdoor: 5°F DB/5°F WB

PIPING

Liquid Size	4 x 1/4" (4 x 6.35 mm)
Gas Size	3/8 x 3/8" (9.52 x 9.52 mm)
Max. Piping Length for all rooms(ft/m)	262 (80)
Max. Piping Length for one IDU(ft/m)	115 (35)
Max. Height Difference of IDU and ODU(ft/m)	49 (15)
Refrigerant Pre-charged Amount(oz/kg)	85 (2.4)
Refrigerant Precharge Length(ft/m)	25 (7.5) x 4
Additional Charge of Refrigerant (Φ6.35 (1/4") liquid pipe) ((oz/ft)/(g/m))	0.16 (15)
Additional Charge of Refrigerant (Φ9.52 (3/8") liquid pipe) ((oz/ft)/(g/m))	0.32 (30)
Connection Method	Flared

Outdoor Unit Dimension

Unit: inch (mm)

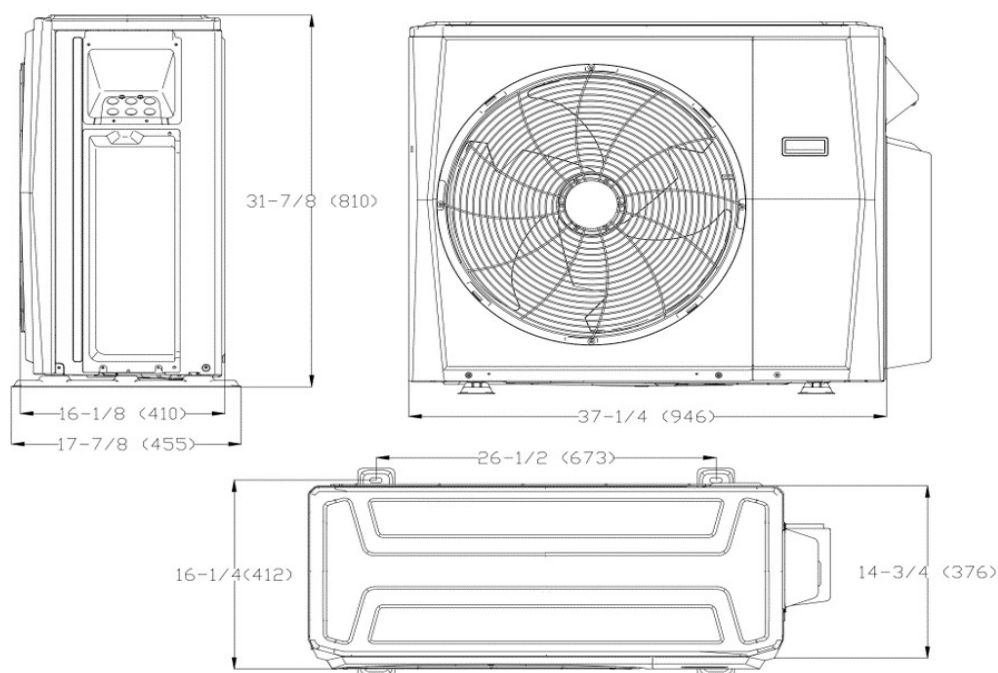

Installation Instruction

