

# R454b Refrigerant

# SUBMITTAL DATA SHEET



Series Name: Multi-Zone High Tier Extreme Heat With Shut-off Valve\_All Ducted  
Model Number: M05HX-H36B-2A

### Multi Zone Heat Pump System

Location:	Approval:
Engineer:	Date:
Submitted to:	Construction:
Submitted by:	Unit #:
Reference:	Drawing #:



### OUTDOOR SPECIFICATION

<b>Compressor Type</b>	TWIN-ROTARY
<b>Compressor Model</b>	EKPQ420D1UMUA
<b>Refrigerant</b>	R454B
<b>Refrigerant Oil Charge(mL)</b>	1460
<b>Refrigerant Oil</b>	VG75
<b>Outdoor Air Flow (Max) (CFM)</b>	3,037.2
<b>Outdoor Noise Level (dBA)</b>	65.0
<b>Dimension (W×D×H)</b>	inch 38-5/8 x 16-5/16 x 38-3/8
	mm 980 x 415 x 975
<b>Package (W×D×H)</b>	inch 45-1/16 x 19-11/16 x 42-1/2
	mm 1,145 x 500 x 1,080
<b>Net/Gross Weight</b>	lbs 212 / 245
	kg 96.1 / 111

### ELECTRICAL

<b>Power Supply</b>	208/230V,60Hz,1Ph
<b>System MCA</b>	37.0
<b>Connection Wiring</b>	AWG 14/4
<b>System MOCP</b>	40.0
<b>Compressor RLA</b>	20.5
<b>Outdoor Fan Motor RLA</b>	2.6
<b>Outdoor Fan Motor W</b>	250
<b>Indoor Fan Motor RLA</b>	/
<b>Indoor Fan Motor W</b>	/
<b>System Power Input @ Cooling (W)</b>	3,000 (600 ~ 4,200)
<b>System Power Input @ Heating (W)</b>	2,780 (600 ~ 3,650)
<b>MCA: Min. circuit amps (A)</b>	<b>MOCP: Max. over current protection (A)</b>
<b>RLA: Rated load amps (A)</b>	<b>W: Fan motor rated output (W)</b>

### EFFICIENCY

Cooling		Heating	
<b>SEER2</b>	19.4	<b>HSPF2-4</b>	10.4
<b>EER2</b>	12	<b>COP</b>	3.8

### PERFORMANCE of Cooling

Cooling (Btu/hr)	
<b>Rated Capacity</b>	36,000
<b>Min/Max Capacity</b>	9,000 ~ 42,000
<b>Moisture Removal(L/h)</b>	2
<b>Standard Operating Range(*F/*C)</b>	-22~122 (-30~50)
Rated Cooling Conditions:	Indoor: 80°F DB/67°F WB Outdoor: 95°F DB/75°F WB

### PERFORMANCE of Heating

Heating (Btu/hr)	
<b>1. @ 47°F Rated</b>	36,000
<b>1. @ 47°F Min/Max Capacity</b>	10,000 ~ 45,000
<b>2. @ 17°F Rated(H32)</b>	33,000
<b>3. @ 5°F Rated: Capacity / COP(H42)</b>	38,000 / 2
<b>3. @ 5°F Max: Capacity</b>	38,000
<b>Standard Operating Range(*F/*C)</b>	-22~75 (-30~24)
1. Conditions:	Indoor: 70°F DB/60°F WB Outdoor: 47°F DB/43°F WB
2. Conditions:	Indoor: 70°F DB/60°F WB Outdoor: 17°F DB/15°F WB
3. Conditions:	Indoor: 70°F DB/60°F WB Outdoor: 5°F DB/5°F WB

### PIPING

<b>Liquid Size</b>	5 x 1/4" (5 x 6.35 mm)
<b>Gas Size</b>	3 x 3/8"+2 x 1/2" (3 x 9.52 mm+2 x 12.7 mm)
<b>Max. Piping Length for all rooms(ft/m)</b>	262 (80)
<b>Max. Piping Length for one IDU(ft/m)</b>	115 (35)
<b>Max. Height Difference of IDU and ODU(ft/m)</b>	49 (15)
<b>Refrigerant Pre-charged Amount(oz/kg)</b>	134 (3.8)
<b>Refrigerant Precharge Length(ft/m)</b>	25 (7.5) x 5
<b>Additional Charge of Refrigerant (Φ6.35 (1/4") liquid pipe) ((oz/ft)/(g/m))</b>	0.16 (15)
<b>Additional Charge of Refrigerant (Φ9.52 (3/8") liquid pipe) ((oz/ft)/(g/m))</b>	0.32 (30)
<b>Connection Method</b>	Flared

Outdoor Unit Dimension

Unit: inch (mm)

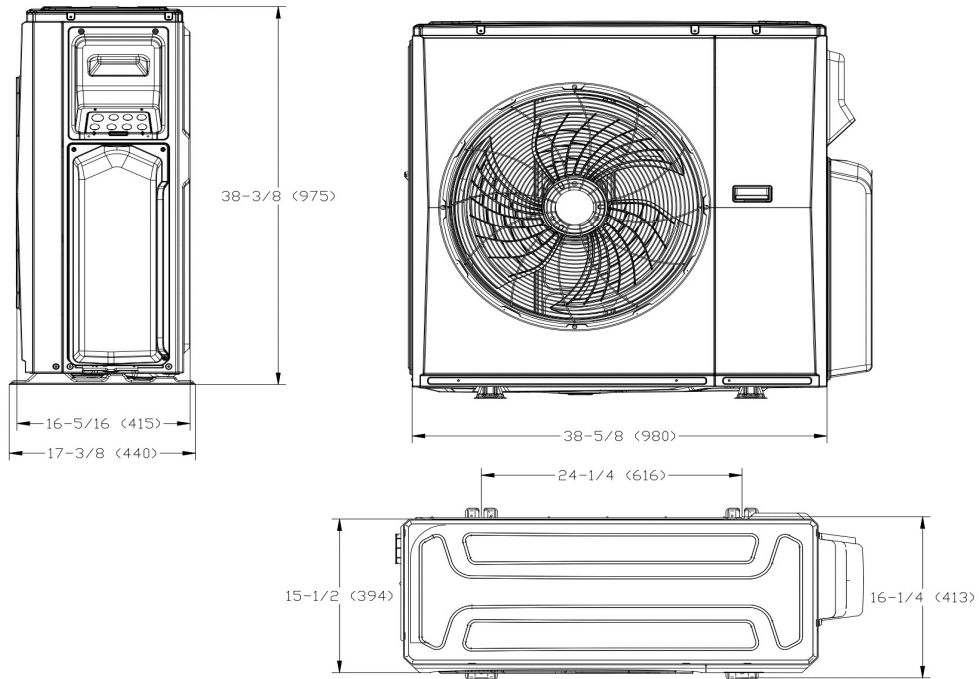

Installation Instruction

