

R454b Refrigerant

SUBMITTAL DATA SHEET



Series Name: Mid Tier - All Easy Pro Advanced Heat Series
Model Number: MSEHU-H09B-2A/MO1ES-H09B-2A

High Wall Mini Split Heat Pump System

Location:	Approval:
Engineer:	Date:
Submitted to:	Construction:
Submitted by:	Unit #:
Reference:	Drawing #:



INDOOR SPECIFICATION

Indoor Air Flow (Turbo/H/M/L/Si) (CFM)	441 / 324 / 230 / 177 / 147
Indoor Noise Level (Turbo/H/M/L/Si) (dBA)	47.5 / 43 / 31 / 18 / 17
Dimension (W×D×H)	inch 31-3/8 x 8-7/8 x 11-5/8
	mm 795 x 225 x 295
Package (W×D×H)	inch 36-1/4 x 12-1/4 x 14-5/8
	mm 920 x 310 x 370
Net/Gross Weight	lbs 23 / 30
	kg 10.6/13.6

OUTDOOR SPECIFICATION

Compressor Type	ROTARY
Compressor Model	KSK103D33UEZ3
Refrigerant	R454B
Refrigerant Oil Charge(mL)	310
Refrigerant Oil	VG74
Outdoor Air Flow (Max) (CFM)	1,235
Outdoor Noise Level (dBA)	52.5
Dimension (W×D×H)	inch 30-1/8 x 11-7/8 x 21-7/8
	mm 765 x 303 x 555
Package (W×D×H)	inch 34-7/8 x 13-1/4 x 24
	mm 887 x 337 x 610
Net/Gross Weight	lbs 63 / 68
	kg 28.2 / 30.7

EFFICIENCY

Cooling		Heating	
SEER2	25.8	HSPF2-4	12.5
EER2	14.9	COP	3.9

PERFORMANCE of Cooling

Cooling (Btu/hr)	
Rated Capacity	9,000
Min/Max Capacity	2,200~13,000
Moisture Removal(L/h)	0.6
Standard Operating Range(*F/°C)	-13~122 (-25 ~ 50)
Conditions:	Indoor: 80°F DB/67°F WB Outdoor: 95°F DB/75°F WB

PERFORMANCE of Heating

Heating (Btu/hr)	
1. @ 47°F Rated	10,000
1. @ 47°F Min/Max Capacity	4,000~13,800
2. @ 17°F Rated	8,100
3. @ 5°F Rated: Capacity / COP	8,000/2.37
3. @ 5°F Max: Capacity	8,000
Standard Operating Range(*F/°C)	-13~75 (-25 ~ 24)
1. Conditions:	Indoor: 70°F DB/60°F WB Outdoor: 47°F DB/43°F WB
2. Conditions:	Indoor: 70°F DB/60°F WB Outdoor: 17°F DB/15°F WB
3. Conditions:	Indoor: 70°F DB/60°F WB Outdoor: 5°F DB/5°F WB

ELECTRICAL

Power Supply	208/230V,60Hz,1Ph
System MCA	12.0
Connection Wiring	AWG 14/4
System MOCP	15.0
Compressor RLA	7.3
Outdoor Fan Motor RLA	0.6
Outdoor Fan Motor W	34
Indoor Fan Motor RLA	0.5
Indoor Fan Motor W	20
System Power Input @ Cooling (W)	600 (180 ~ 990)
System Power Input @ Heating (W)	750 (230 ~ 1,130)
MCA: Min. circuit amps (A)	MOCP: Max. over current protection (A)
RLA: Rated load amps (A)	W: Fan motor rated output (W)

PIPING

Throttle type(Indoor)	N/A
Throttle type(Outdoor)	EXV
Liquid Size	1/4" (6.35mm)
Gas Size	3/8" (9.52mm)
Max. Piping Length(ft/m)	82 (25)
Max. Height Difference(ft/m)	49 (15)
Max. Pre-charged Length(ft/m)	25 (7.5)
Refrigerant Pre-charged Amount(oz/g)	32 (0.92)
Additional Charge of Refrigerant((oz/ft)/(g/r	0.16 (15)
Connection Method	Flared

Indoor Unit Dimension

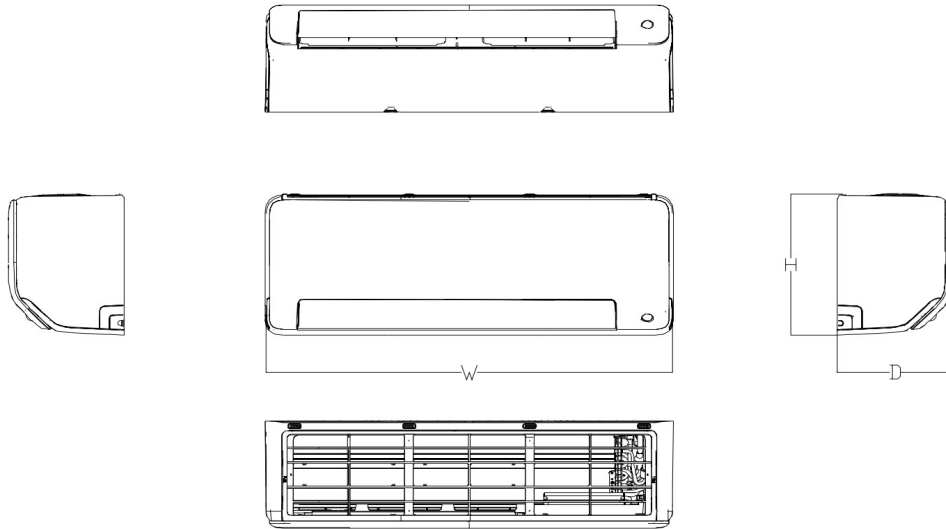

Capacity	Body Code	Unit	W	D	H
9k-15K	B	mm	795	225	295
		inch	31-3/8	8-7/8	11-5/8
18K	C	mm	965	239	319
		inch	38	9-3/8	12-1/2
24k-36K	D	mm	1140	275	370
		inch	44-7/8	10-7/8	14-1/2

Installation Instruction

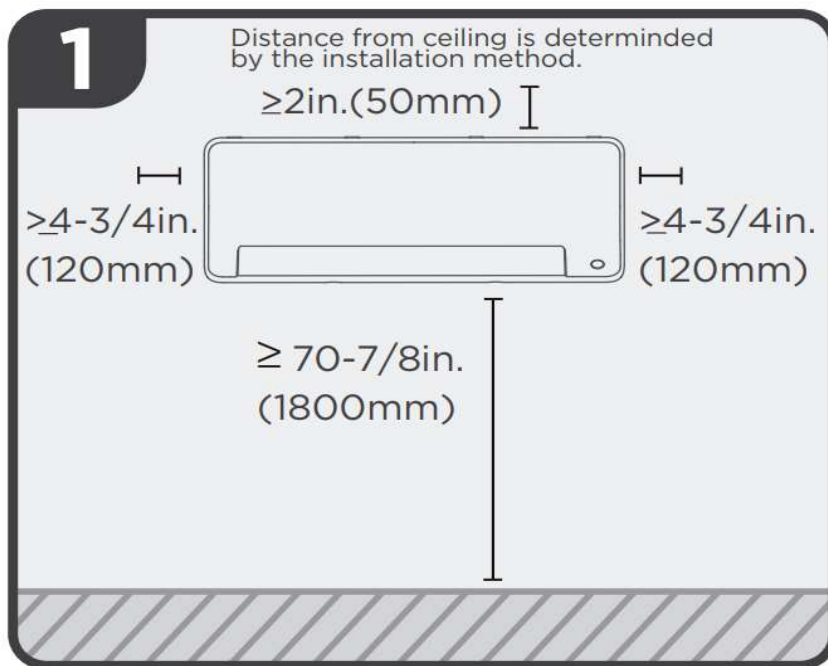

Select Installation Location

Outdoor Unit Dimension

Unit: inch (mm)

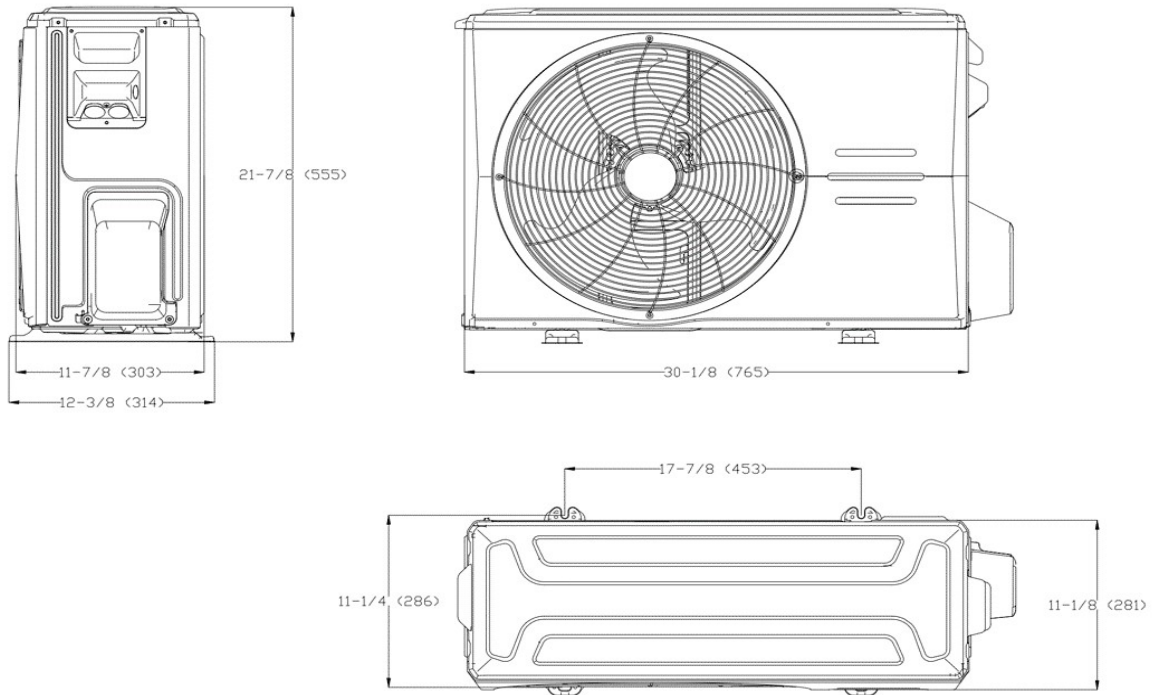

Installation Instruction

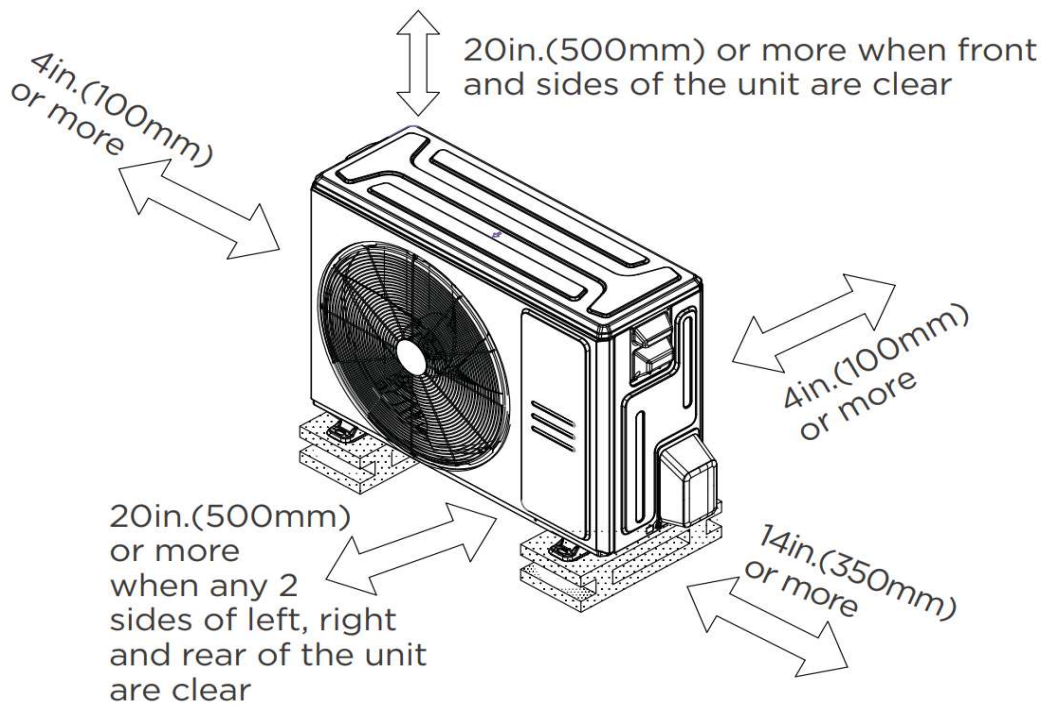

FEATURES

- Intelligent eye
- Easy maintenance design
- Indoor unit TU1 copper coil
- Humidity control
- 1~100% fan speed setting
- WiFi capability: through WiFi dongle or wired controller with built-in WiFi
- OTA(by using WiFi dongle)
- Multiple control options available:
 - Wireless remote controller RG10 (Built-In)
 - Two-way communication wired controller with built-in Wi-Fi:120N(X6W)
 - Midea Smart Thermostat: MTL04-1
 - Third-Party 24V Thermostat*

*Midea 24V Mini Interface Kit (17222000A68532) is required.