

R454b Refrigerant

SUBMITTAL DATA SHEET



Series Name: Slim Duct Xtreme Heat Series
Model Number: MDLHU-H09B-2A/MO1HS-H09B-2A

Slim Duct Heat Pump System

Location:	Approval:
Engineer:	Date:
Submitted to:	Construction:
Submitted by:	Unit #:
Reference:	Drawing #:



INDOOR SPEINDOOR SPECIFICATIONCIFICATION

Indoor Air Flow (Turbo/H/M/L/Si) (CFM)	324 / 265 / 206 / 147 / 118
Indoor Noise Level (Turbo/H/M/L/Si) (dBA)	33 / 33 / 31 / 30 / 23
Indoor static pressure range	0-0.4
Dimension (W×D×H)	inch 27-1/2 x 20 x 7-7/8
	mm 700 × 506 × 200
Package (W×D×H)	inch 33-7/8 x 21-1/4 x 11-1/4
	mm 860 × 540 × 285
Net/Gross Weight	lbs 39 / 47
	kg 17.9 / 21.2

OUTDOOR SPECIFICATION

Compressor Type	ROTARY
Compressor Model	KTN110D42UFZ
Refrigerant	R454B
Refrigerant Oil Charge(mL)	350
Refrigerant Oil	VG74
Outdoor Air Flow (Max) (CFM)	1,472
Outdoor Noise Level (dBA)	56
Dimension (W×D×H)	inch 31-3/4 x 13 x 21-3/4
	mm 805 × 330 × 554
Package (W×D×H)	inch 36 x 14-5/8 x 24-1/4
	mm 915 × 370 × 615
Net/Gross Weight	lbs 73 / 79
	kg 33 / 35.7

EFFICIENCY

Cooling		Heating	
SEER2	21.4	HSPF2-4	12.5
EER2	13.4	COP	3.53

PERFORMANCE of Cooling

Cooling (Btu/hr)	
Rated Capacity	9,000
Min/Max Capacity	3,400~13,500
Moisture Removal(L/h)	0.73
Standard Operating Range(°F/°C)	-22 ~ 122 (-30 ~ 50)
Conditions:	Indoor: 80°F DB/67°F WB Outdoor: 95°F DB/75°F WB

PERFORMANCE of Heating

Heating (Btu/hr)	
1. @ 47°F Rated	10,000
1. @ 47°F Min/Max Capacity	3,800~16,200
2. @ 17°F Rated	9,600
3. @ 5°F Rated: Capacity / COP	11,200/1.89
3. @ 5°F Max: Capacity	11,200
Standard Operating Range(°F/°C)	-22 ~ 75 (-30 ~ 24)
1. Conditions:	Indoor: 70°F DB/60°F WB Outdoor: 47°F DB/43°F WB
2. Conditions:	Indoor: 70°F DB/60°F WB Outdoor: 17°F DB/15°F WB
3. Conditions	Indoor: 70°F DB/60°F WB Outdoor: 5°F DB/5°F WB

ELECTRICAL

Power Supply	208/230V,60Hz,1Ph
System MCA	15.0
Connection Wiring	AWG 14/4
System MOCP	15.0
Compressor RLA	10.4
Outdoor Fan Motor RLA	0.6
Outdoor Fan Motor W	34
Indoor Fan Motor RLA	1.2
Indoor Fan Motor W	81
System Power Input @ Cooling (W)	667 (145 ~ 1,200)
System Power Input @ Heating (W)	830 (260 ~ 1,450)
MCA: Min. circuit amps (A)	MOCP: Max. over current protection (A)
RLA: Rated load amps (A)	W: Fan motor rated output (W)

PIPING

Throttle type(Indoor)	N/A
Throttle type(Outdoor)	EXV
Liquid Size	1/4" (6.35 mm)
Gas Size	3/8" (9.52 mm)
Max. Piping Length(ft/m)	82 (25)
Max. Height Difference(ft/m)	33 (10)
Max. Pre-charged Length(ft/m)	25 (7.5)
Refrigerant Pre-charged Amount(oz/kg)	35 (1.00)
Additional Charge of Refrigerant((oz/ft)/(g/m)	0.16 (15)
Connection Method	Flared

Indoor Unit Dimension

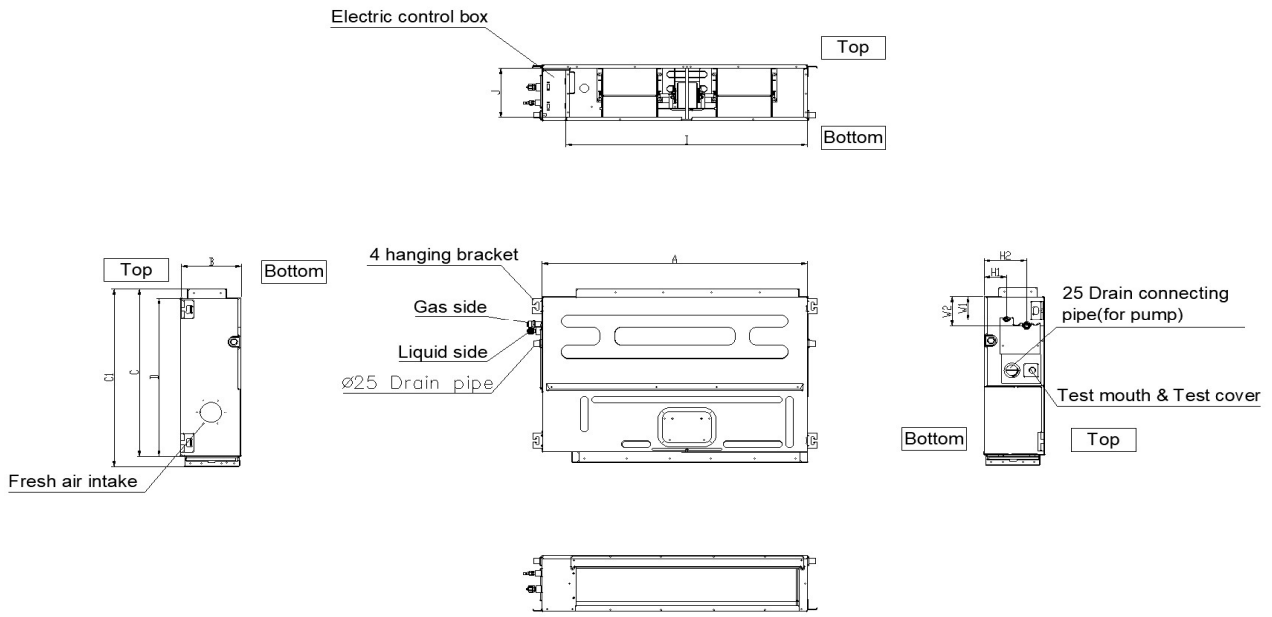

Model(kBtu/h)	unit	A	B	C	C1	D
	6 -12	mm	700	200	470	506
in		27-1/2	7-7/8	18-1/2	20	17-3/4
18	mm	880	210	634	674	600
	in	34-5/8	8-1/4	25	26-1/2	23-5/8

Installation Instruction

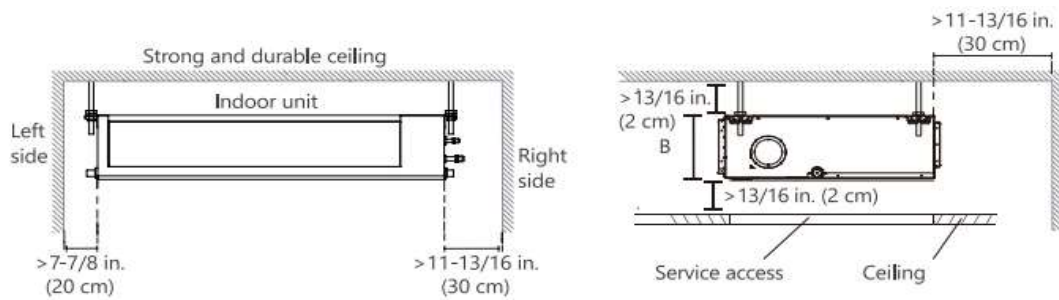

Outdoor Unit Dimension

Unit: inch (mm)

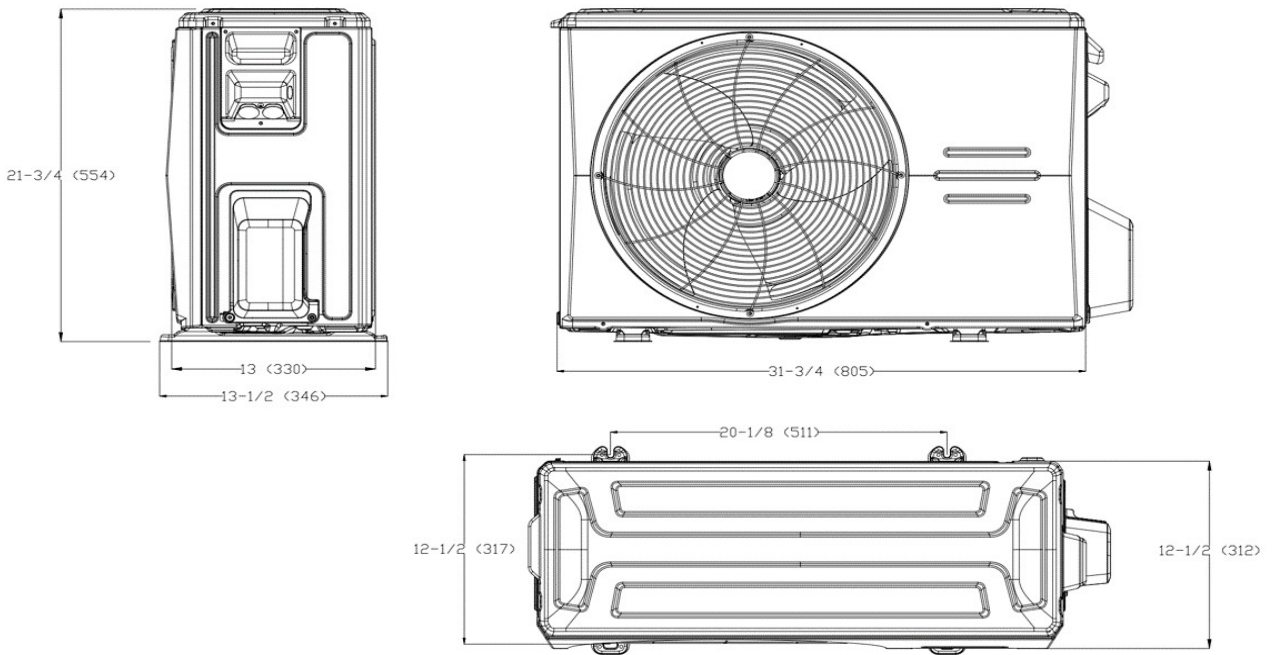

Installation Instruction

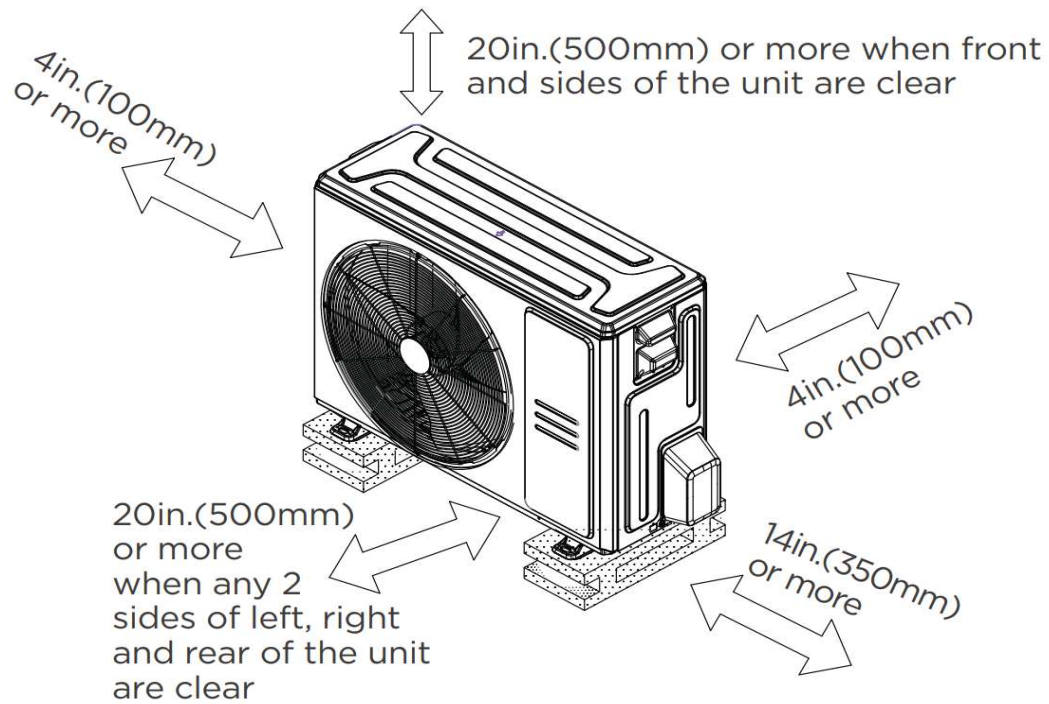

Fan performance

The default setting is SP1, which can be changed to SP2,3,4, using the wired controller.

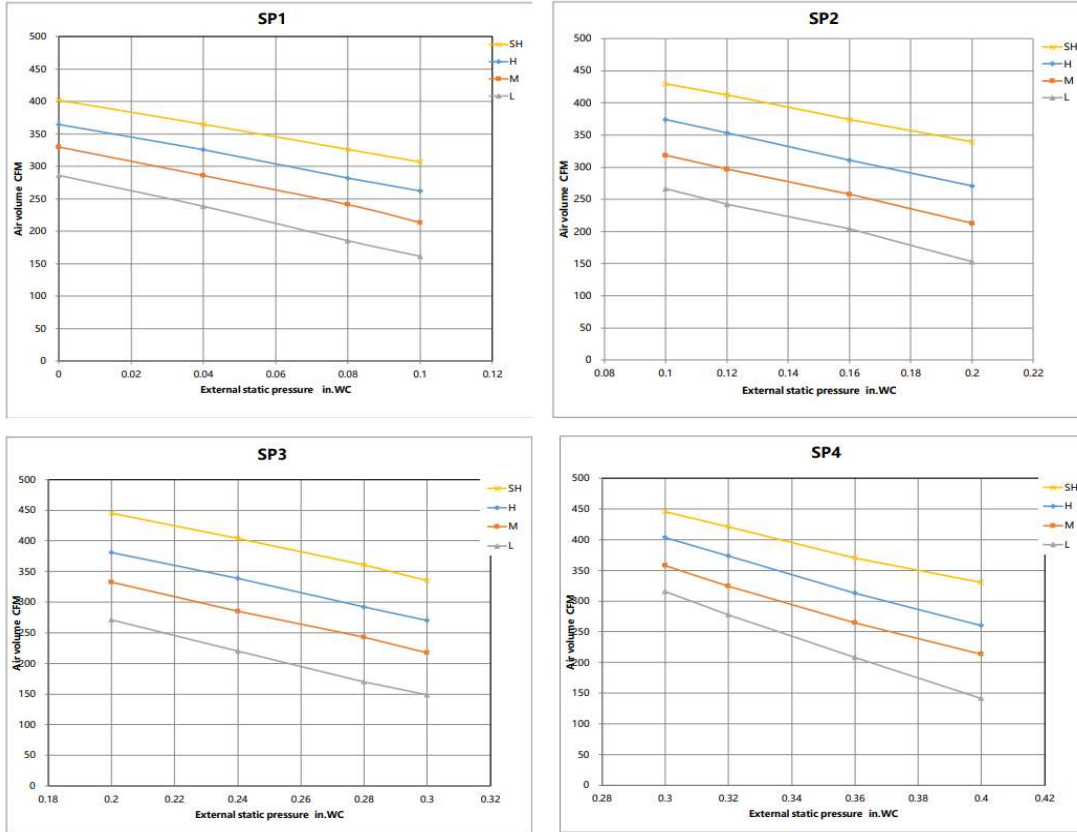

Constant airflow

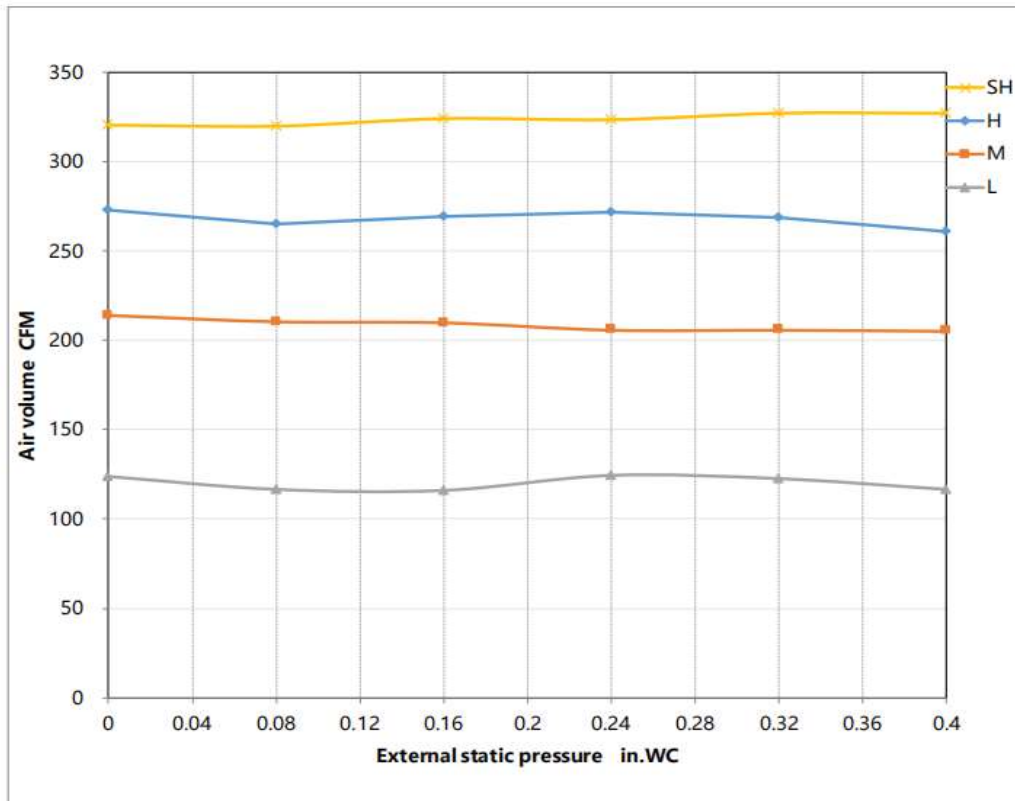

FEATURES

- Compatible with both horizontal and vertical installation(Optional)
- Static pressure setting stages: 4
- Refrigerant leakage detection sensor
- Constant airflow
- Built-in pump
- i-clean
- Fan speed stages: 1~100%
- WiFi capability: Wired controller with built-in WiFi
- OTA(by using wired controller 120N(X6W))
- 2-pin connector(HA/HB) for programmable wired controller
- Multiple control options available:
 - Two way communication wired controller with built-in WiFi:120N(X6W)
 - Wireless remote controller
 - Third-Party 24V Thermostat*

*24V interface is required.