

R454b Refrigerant

SUBMITTAL DATA SHEET



Series Name: Slim Duct Xtreme Heat Series
Model Number: MDHHS-H60B-2A/MO1HU-H60B-2A

Slim Duct Heat Pump System

Location:	Approval:
Engineer:	Date:
Submitted to:	Construction:
Submitted by:	Unit #:
Reference:	Drawing #:



INDOOR SPEINDOOR SPECIFICATIONCIFICATION

Indoor Air Flow (Turbo/H/M/L/Si) (CFM)	2001 / 1707 / 1413 / 1118 / 1118
Indoor Noise Level (Turbo/H/M/L/Si) (dBA)	52 / 52 / 48 / 42 / 41
Indoor static pressure range(in.w.g.)	0-0.8
Dimension (W×D×H)	inch 55-1/8 x 31-1/2 x 15
	mm 1400 × 800 × 380
Package (W×D×H)	inch 63 x 36 x 17-1/2
	mm 1600 × 915 × 445
Net/Gross Weight	lbs 161 / 178
	kg 73.2 / 80.8

OUTDOOR SPECIFICATION

Compressor Type	TWIN-ROTARY
Compressor Model	EKPQ440D1UMUB
Refrigerant	R454B
Refrigerant Oil Charge(mL)	1300
Refrigerant Oil	VG75
Outdoor Air Flow (Max) (CFM)	4,238
Outdoor Noise Level (dBA)	63
Dimension (W×D×H)	inch 37-1/2 x 16-3/8 x 52-1/2
	mm 952 × 416 × 1333
Package (W×D×H)	inch 43-1/8 x 19-1/2 x 57-1/2
	mm 1095 × 495 × 1460
Net/Gross Weight	lbs 230 / 262
	kg 104.5 / 118.7

EFFICIENCY

Cooling		Heating	
SEER2	15.8	HSPF2-4	10.4
EER2	10.2	COP	3.74

PERFORMANCE of Cooling

Cooling (Btu/hr)	
Rated Capacity	55,000
Min/Max Capacity	14,200~60,000
Moisture Removal(L/h)	3.63
Standard Operating Range(°F/°C)	-22 ~ 122 (-30 ~ 50)
Conditions:	Indoor: 80°F DB/67°F WB Outdoor: 95°F DB/75°F WB

PERFORMANCE of Heating

Heating (Btu/hr)	
1. @ 47°F Rated	60,000
1. @ 47°F Min/Max Capacity	11,200~66,000
2. @ 17°F Rated	45,000
3. @ 5°F Rated: Capacity / COP	53,500/2.10
3. @ 5°F Max: Capacity	53,500
Standard Operating Range(°F/°C)	-22 ~ 75 (-30 ~ 24)
1. Conditions:	Indoor: 70°F DB/60°F WB Outdoor: 47°F DB/43°F WB
2. Conditions:	Indoor: 70°F DB/60°F WB Outdoor: 17°F DB/15°F WB
3. Conditions	Indoor: 70°F DB/60°F WB Outdoor: 5°F DB/5°F WB

ELECTRICAL

Power Supply	208/230V,60Hz,1Ph
System MCA	44.0
Communication Wiring	AWG 20/2
System MOCP	45.0
Compressor RLA	26.8
Outdoor Fan Motor RLA	2.2
Outdoor Fan Motor W	85
Indoor Fan Motor RLA	4.0
Indoor Fan Motor W	560
System Power Input @ Cooling (W)	5,400 (1,160 ~ 6,120)
System Power Input @ Heating (W)	4,700 (795 ~5,150)
MCA: Min. circuit amps (A)	MOCP: Max. over current protection (A)
RLA: Rated load amps (A)	W: Fan motor rated output (W)

PIPING

Throttle type(Indoor)	N/A
Throttle type(Outdoor)	EXV+Throttle valve
Liquid Size	3/8" (9.52mm)
Gas Size	3/4" (19mm)
Max. Piping Length(ft/m)	246 (75)
Max. Height Difference(ft/m)	98 (30)
Max. Pre-charged Length(ft/m)	25 (7.5)
Refrigerant Pre-charged Amount(oz/kg)	152 (4.30)
Additional Charge of Refrigerant((oz/ft)/(g/m)	0.32 (30)
Connection Method	Flared

Indoor Unit Dimension

Air outlet dimensions

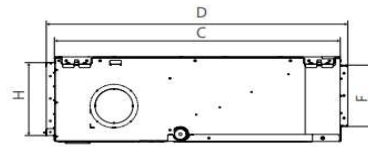
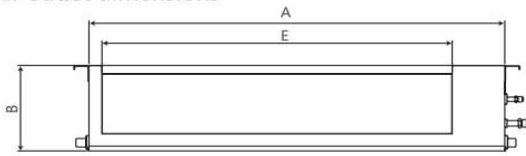

Air inlet dimensions

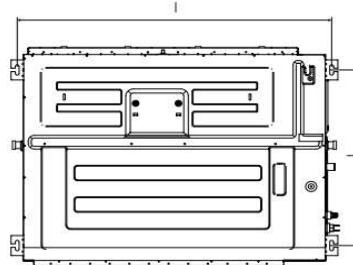
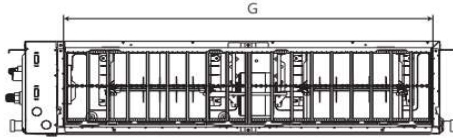

Unit: inch (mm)

MODEL	OUTLINE DEMENSION				AIR OUTLET OPENING SIZE		AIR RETURN OPENING SIZE		SIZE OF MOUNTED LUG	
	A	B	C	D	E	F	G	H	I	J
9K/12K	27-5/8 (700)	9-5/8 (245)	29-1/2 (750)	31-5/16 (795)	20-3/4 (527)	7 (178)	23-5/16 (592)	8-5/16 (212)	29-3/32 (740)	25-1/4 (640)
18K/24K	39-7/16 (1,000)	9-5/8 (245)	29-1/2 (750)	31-5/16 (795)	32-5/8 (827)	7 (178)	35-3/32 (892)	8-5/16 (212)	40-7/8 (1,040)	25-1/4 (640)
36K/48K	47-1/4 (1,200)	11-13/16 (300)	29-1/2 (750)	31-5/16 (795)	40-7/16 (1,027)	9-1/4 (233)	43 (1,092)	10-1/2 (267)	48-13/16 (1,240)	25-1/4 (640)
55K/60K	55-3/32 (1,400)	14-7/8 (380)	29-1/2 (750)	31-5/16 (795)	48-3/32 (1,223)	12-5/8 (320)	50-3/32 (1,272)	13 (330)	56-13/16 (1,440)	26-5/16 (668)

Installation Instruction

1) Ceiling-mounted

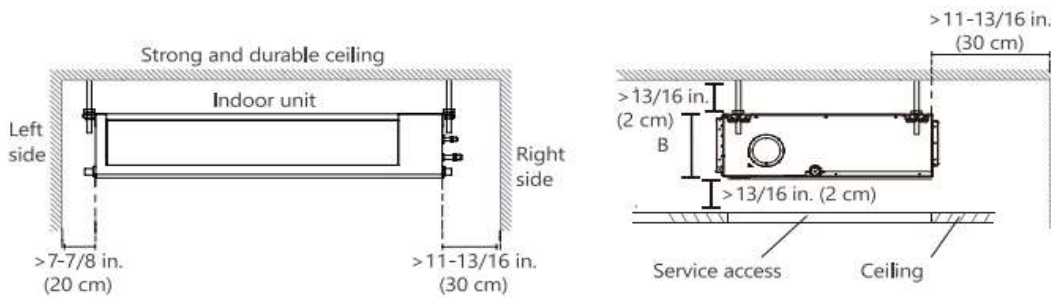

2) Wall-mounted

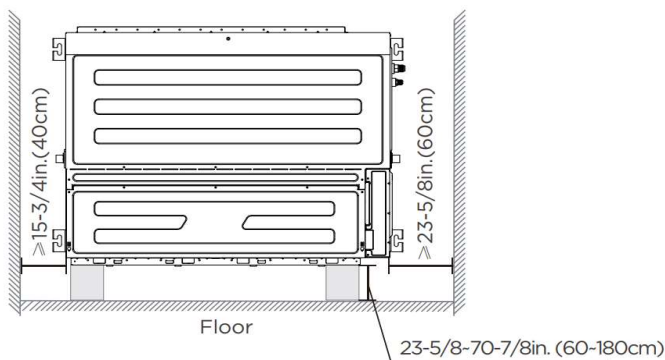

Outdoor Unit Dimension

Unit: inch (mm)

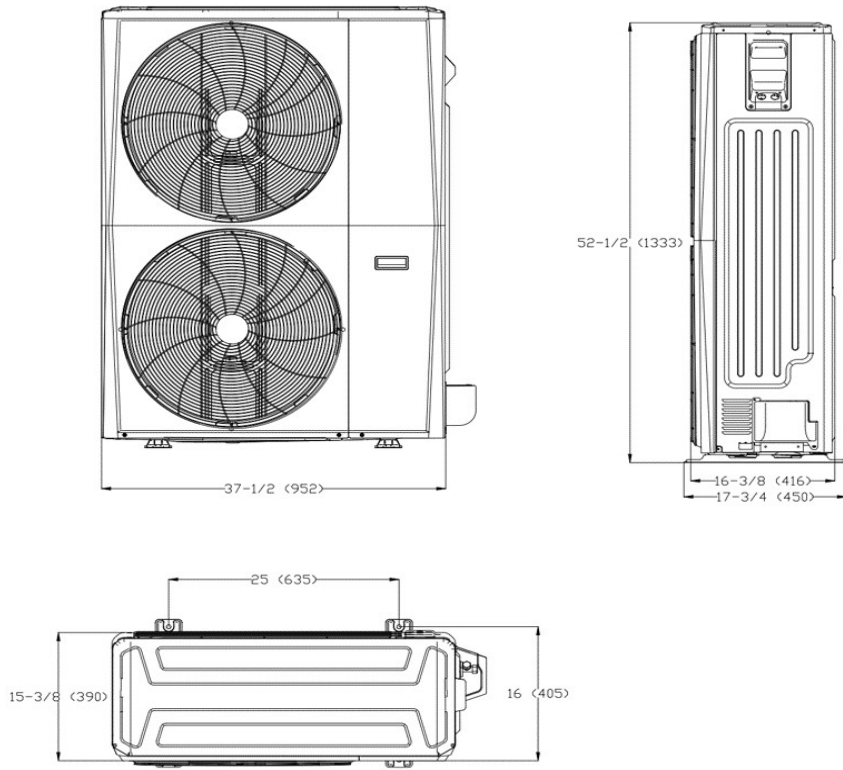

Installation Instruction

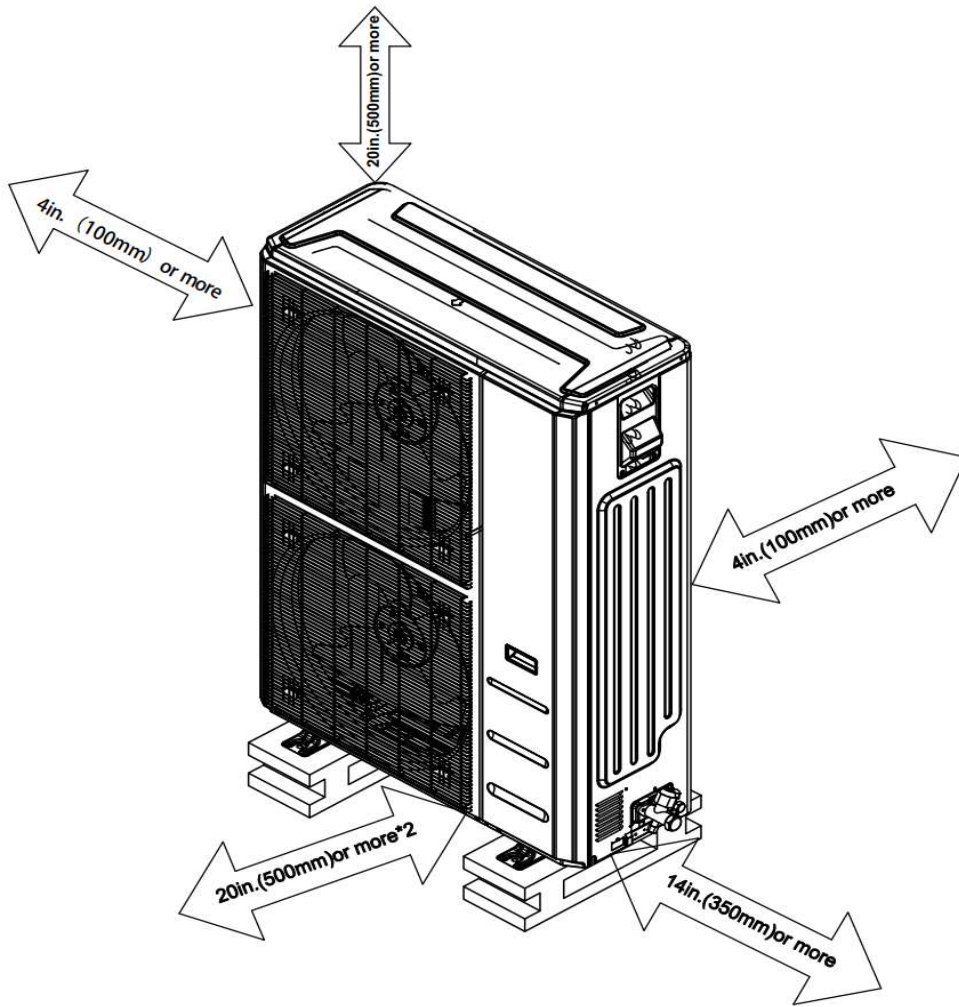

Fan performance

The default setting is SP1, which can be changed to SP2,3,4,5,6,7,8 using the wired controller.

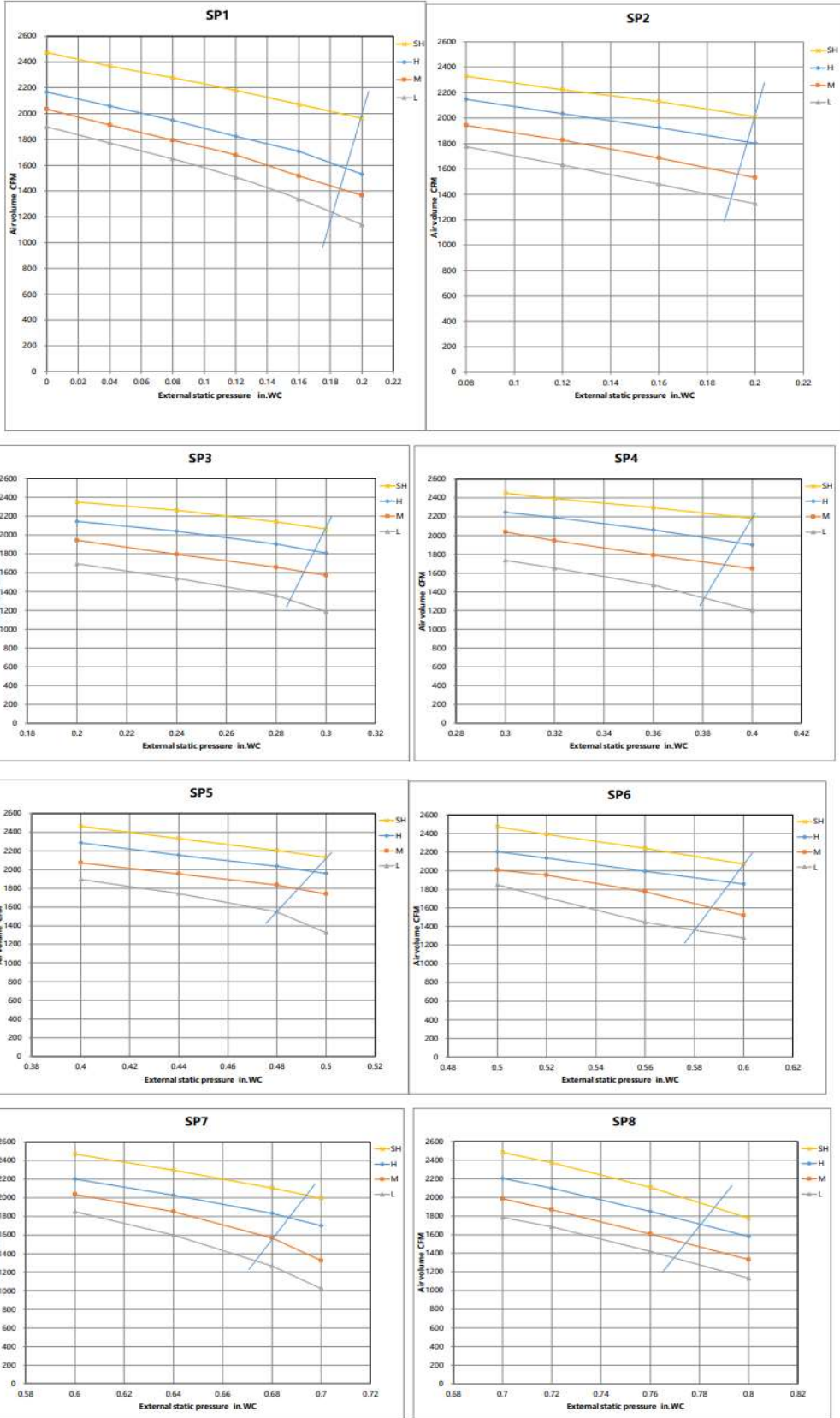

Constant air volume

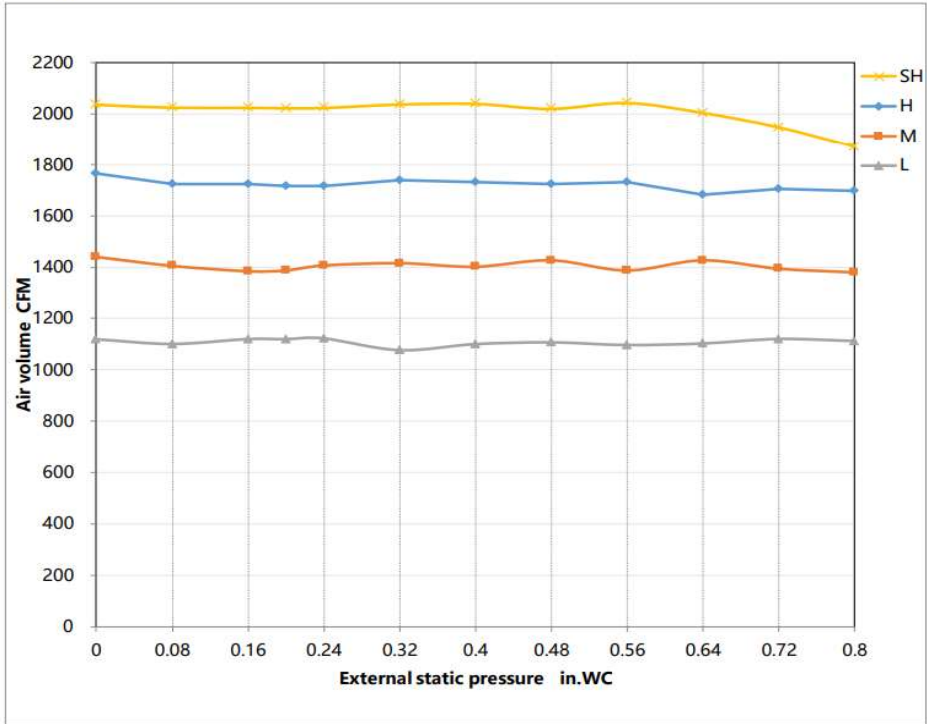

FEATURES

- Compatible with both horizontal and vertical installation
- Static pressure up to 0.8 in.w.g(for all models)
- Static pressure setting stages: 8
- Refrigerant leakage detection sensor
- Constant airflow
- Built-in pump
- i-clean
- Fan speed stages: 1~100%
- WiFi capability: through wired controller with built-in WiFi
- OTA(by using wired controller 120N(X6W))
- 2-pin connector(HA/HB) for programmable wired controller
- Multiple control options available:
 - Two way communication wired controller with built-in WiFi:120N(X6W)
 - Wireless remote controller
 - Third-Party 24V Thermostat*

*24V interface is required.