

R454b Refrigerant

SUBMITTAL DATA SHEET



Series Name: Advanced Heat Ceiling-Mounted AHU Series
Model Number: MAPHE-H30B-2A/MO1BE-H30B-2A

Air Handler Heat Pump System

Location:	Approval:
Engineer:	Date:
Submitted to:	Construction:
Submitted by:	Unit #:
Reference:	Drawing #:



INDOOR SPECIFICATION

ESP(in.W.G)	0-0.8	
Indoor Air Flow (Turbo/H/M/L/Si) (CFM)	989 / 895 / 806 / 542 / 542	
Indoor Noise Level (Turbo/H/M/L/Si) (dBA)	60.5 / 60.5 / 58.5 / 50 / 50	
Dimension (W×D×H)	inch	55-1/4 x 23.33 x 10.93
	mm	1403 x 593 x 278
Package (W×D×H)	inch	59-1/4 x 26-3/4 x 13-5/8
	mm	1505 x 680 x 345
Net/Gross Weight	lbs	138.89/151.01
	kg	63/68.5

OUTDOOR SPECIFICATION

Compressor Type	ROTARY	
Compressor Model	KTF250D22UMT	
Refrigerant	R454B	
Refrigerant Oil Charge(mL)	670	
Refrigerant Oil	VG74	
Outdoor Air Flow (Max) (CFM)	3,002	
Outdoor Noise Level (dBA)	59	
Dimension (W×D×H)	inch	37-1/4 x 16-1/8 x 31-7/8
	mm	946 x 410 x 810
Package (W×D×H)	inch	42-7/8 x 19-5/8 x 34-7/8
	mm	1090 x 500 x 885
Net/Gross Weight	lbs	142 / 152
	kg	64.3 / 69.1

EFFICIENCY

Cooling		Heating	
SEER2	16.6	HSPF2-4	8.1
EER2	10.5	COP	3.2

PERFORMANCE of Cooling

Cooling (Btu/hr)	
Rated Capacity	30,000
Min/Max Capacity	7,300~33,400
Moisture Removal(L/h)	2.66
Standard Operating Range(°F/°C)	-13~122(-25 ~ 50)
Rated Cooling Conditions:	Indoor: 80°F DB/67°F WB Outdoor: 95°F DB/75°F WB

PERFORMANCE of Heating

Heating (Btu/hr)	
1. @ 47°F Rated	30,000
2. @ 47°F Min/Max Capacity	5,700~31,000
3. @ 17°F Rated	19,000
4. @ 5°F Rated: Capacity / COP	19,000/1.9
5. @ 5°F Max: Capacity	19,000
Standard Operating Range(°F/°C)	-13~75(-25 ~ 24)
1. Rated Heating Conditions:	Indoor: 70°F DB/60°F WB Outdoor: 47°F DB/43°F WB
2. Rated Heating Conditions:	Indoor: 70°F DB/60°F WB Outdoor: 17°F DB/15°F WB
3. Heating Conditions, Compressor Operating at Max. Frequency	Indoor: 70°F DB/60°F WB Outdoor: 5°F DB/5°F WB

ELECTRICAL

Indoor Power Supply	115/208/230,60Hz,1Ph
Indoor MCA 115V/(208/230V)	115V:8A; 208/230V:6A
Indoor MOP	15.0
Outdoor Power Supply	208/230,60Hz,1Ph
Outdoor MCA	22.5
Outdoor MOP	25.0
Communication Wiring	AWG 20/2
Compressor RLA	17
Outdoor Fan Motor RLA	1.1
Outdoor Fan Motor W	120
Indoor Fan Motor RLA	115V:6.4A 208/230V:4.5A
Indoor Fan Motor W	375
System Power Input @ Cooling (W)	2,857(500 ~ 3,130)
System Power Input @ Heating (W)	2,748(485 ~ 2,748)
MCA: Min. circuit amps (A)	MOCP: Max. over current protection (A)
RLA: Rated load amps (A)	W: Fan motor rated output (W)

PIPING

Throttle type(Indoor)	EXV
Throttle type(Outdoor)	EXV
Liquid Size	3/8" (9.52mm)
Gas Size	3/4" (19mm)
Max. Piping Length(ft/m)	246(75)
Max. Height Difference(ft/m)	98(30)
Max. Pre-charged Length(ft/m)	25(7.5)
Refrigerant Pre-charged Amount(oz/kg)	92(2.6)
Additional Charge of Refrigerant(oz/ft)/(g/m)	0.7(65)
Connection Method	Flared

Indoor Unit Dimension

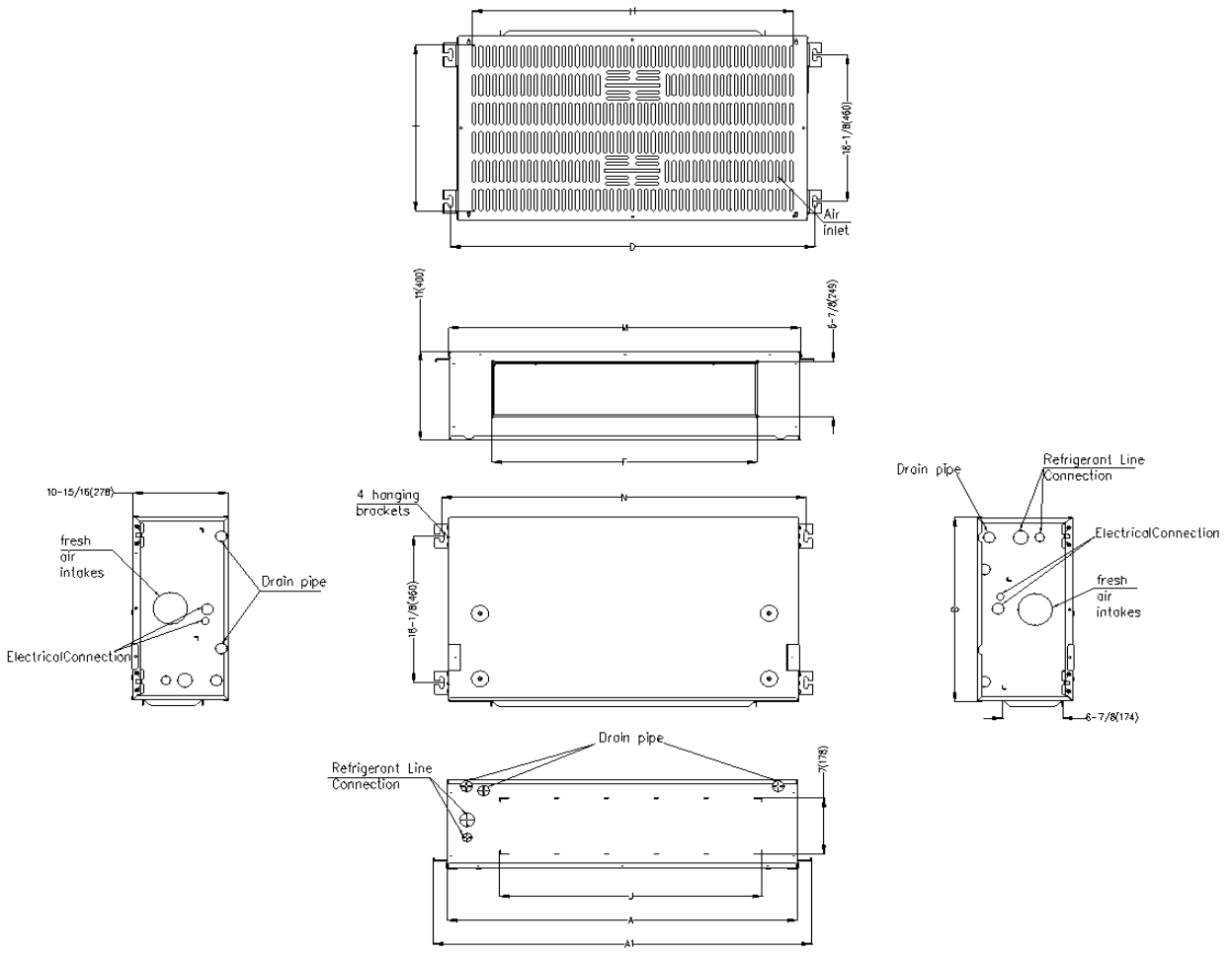

	18K		24K		30K		36K	
	inch	mm	inch	mm	inch	mm	inch	mm
A	39-15/16	1015	45-7/8	1165	51-15/16	1320	58-7/8	1495
A1	43-1/4	1098	49-1/8	1248	55-1/4	1403	62-1/8	1578
J	30	761	35-7/8	911	41-15/16	1066	48-7/8	1241
D	41-5/8	1057	47-1/2	1207	53-5/8	1362	60-1/2	1537
F	30-1/4	769	36-3/16	919	42-5/16	1074	49-3/16	1249
H	36-5/8	930	39-3/4	1010	47-5/8	1210	53-15/16	1370
M	40-3/16	1020	46-1/16	1170	52-3/16	1325	59-1/16	1500
N	41-5/8	1057	40-7/16	1027	53-5/8	1362	60 1/2	1537

Outdoor Unit Dimension

Unit:inch(mm)

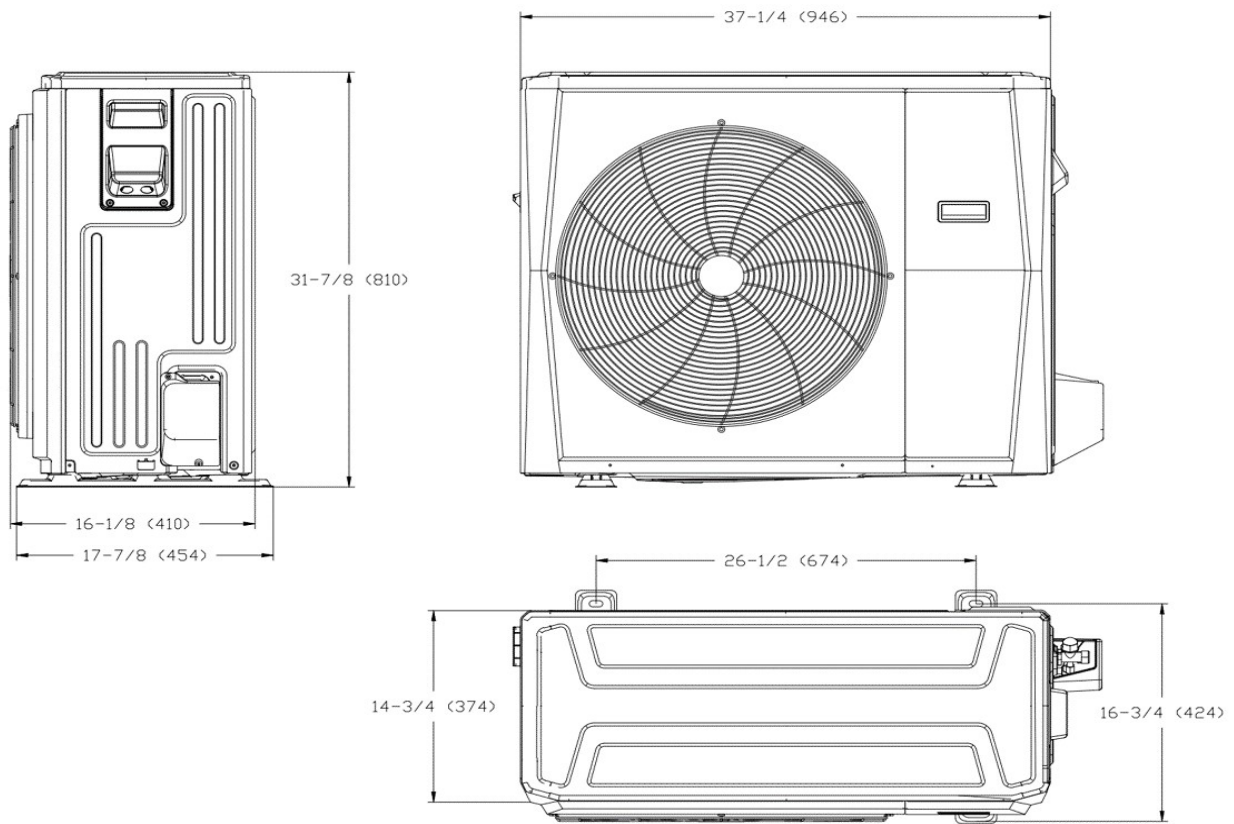

Installation Instruction For Outdoor Unit

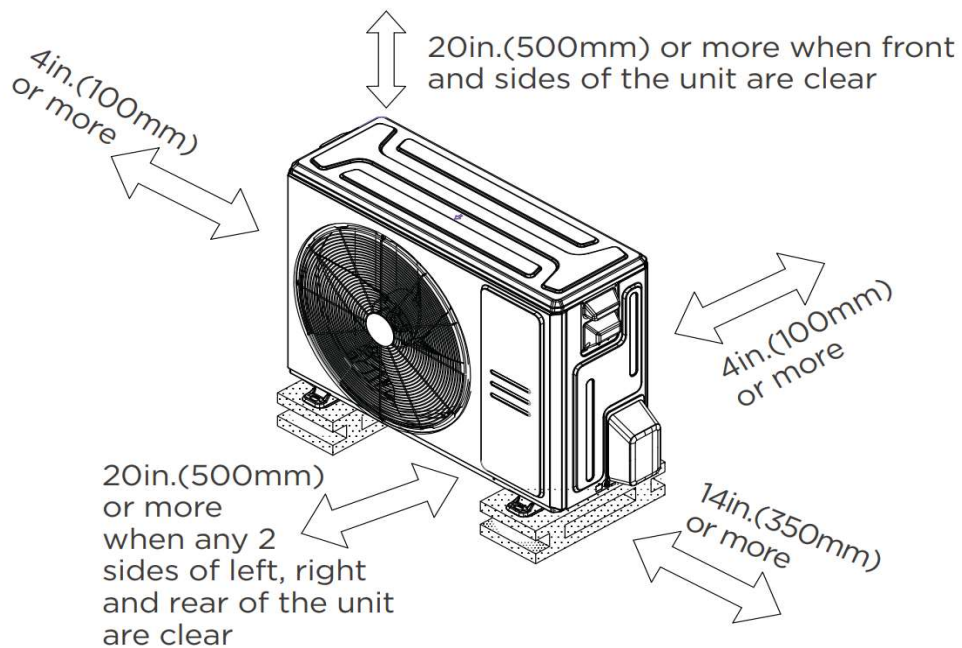

Fan Performance For Indoor Unit

30K

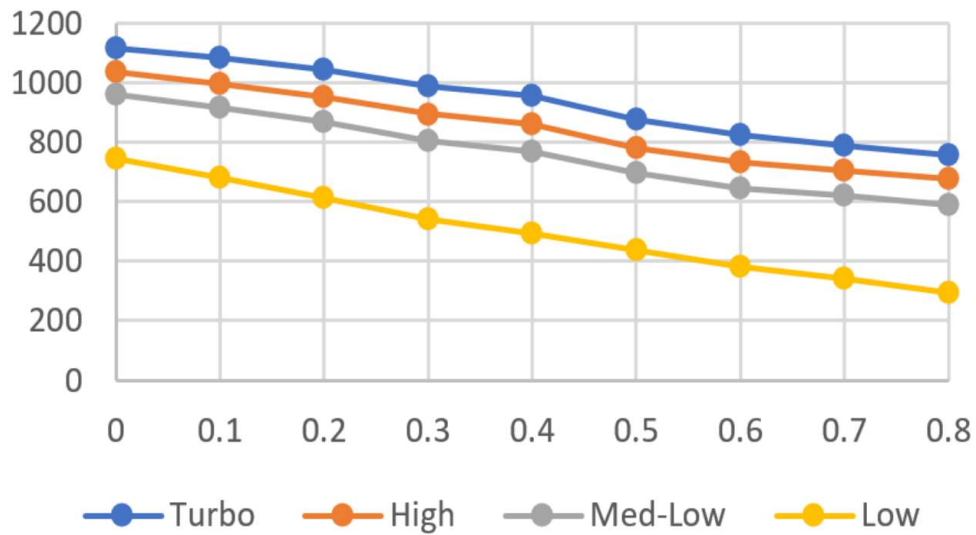

Features

- Downward or backward (optional) air inlet
- Aluminum Coil
- The IDU supports 115/230V voltage compatibility
- Constant Torque System: Up to 0.80 In.W.C.
- Optional Auxiliary heat kit up to 10kW
- Easy Maintenance
- Multiple control options available:
 - Two-way communication wired controller with built-in Wi-Fi: 120N (X6W)
 - Wireless remote controller
 - Third-Party 24V Thermostat
- Adaptive control systems with 24V and RS485 communication
- High efficiency up to 17.5 SEER2, 12 EER2, 10.5 HSPF2
- Base pan heater and crankcase heater are equipped as standard